

PARTS MANUAL

**C80ZHD (A282)
C60ZHD (A373)**

CUSTOMER EDITION

HYSTER

SECTIONS

1	FRAME/DRIVE UNIT
2	ELECTRICAL SYSTEM
3	STEER HANDLE/BRAKE SYSTEM
4	LIFT LINKAGE AND FORKS
5	HYDRAULIC SYSTEM
6	OPTIONS
7	FIELD CONVERSION KITS
8	NUMERICAL INDEX

This Parts Manual is divided into 8 major sections which are listed above. Quick reference to these sections can be made by placing the right thumb on the tab of the desired section, bending the book back and thumbing the pages to the corresponding tab.

**Thanks very much for your reading,
Want to get more information,
Please click here, Then get the complete
manual**

JustClickHere 

NOTE:

**If there is no response to click on the link above,
please download the PDF document first, and then
click on it.**

**Have any questions please write to me:
admin@servicemanualperfect.com**

TABLE OF CONTENTS

DESCRIPTION	PAGE
A	
AUDIBLE ALARM	6-6
B	
BATTERY DISCONNECT	2-8
BATTERY RETENTION	1-7
BATTERY ROLLER ASSEMBLY	1-8
BRAKE ASSEMBLY	
A282	3-16
A373	3-17
C	
CASTER ASSEMBLY	4-18
CONTACTOR ASSEMBLY	
SUB-ZERO	2-10
WASH-DOWN	2-11
CONTROL MODULE AND ATTACHING HARDWARE	2-9
CONVENIENCE TRAY	
WITHOUT LOAD BACKREST EXTENSION	6-7
COVERS AND FLOORMAT	1-10
D	
DASH DISPLAY	2-4
DECALS	1-12
DRIVE WHEEL AND TIRE	
AND STATIC STRAP	1-6
E	
ELECTRICAL	2-2
ENTRY ROLLER	4-20
F	
FORK TIP SKID	4-21
H	
HIGH SPEED FOOT PEDAL	2-6
HYDRAULIC POWER UNIT	5-2
J	
JUMPER HARNESS	
PARK BRAKE SWITCH	2-30
L	
LIFT CYLINDER ASSEMBLY	5-4
LIFT LINKAGE	4-2
LOAD WHEELS	
DUAL WHEEL, 2 BEARINGS	4-11
DUAL WHEEL, 4 BEARINGS	4-12
DUAL WHEEL, 4 BEARINGS - ALTERNATE CONFIGURATION	4-13
SINGLE WHEEL, FOUR BEARINGS	4-8

TABLE OF CONTENTS (continued)

DESCRIPTION	PAGE
SINGLE WHEEL, FOUR BEARINGS - SEALED	4-9
SINGLE WHEEL, FOUR BEARINGS - SEALED - ALTERNATE CONFIGURATION	4-10
SINGLE WHEEL, TWO BEARINGS	4-5
SINGLE WHEEL, TWO BEARINGS - SEALED	4-6
SINGLE WHEEL, TWO BEARINGS - SEALED - ALTERNATE CONFIGURATION	4-7
TANDEM ASSEMBLY, LUBED BEARING - A282	4-14
TANDEM ASSEMBLY, LUBED BEARING - ALTERNATE CONFIGURATION (A282)	4-15
TANDEM ASSEMBLY, SEALED BEARING - A282	4-16
TANDEM ASSEMBLY, SEALED BEARING - ALTERNATE CONFIGURATION (A282)	4-17
M	
MASTER DRIVE UNIT	
CARRIER	1-16
CARRIER - SUB-ZERO OPTION	1-23
DRIVE	1-18
DRIVE - SUB-ZERO OPTION	1-25
HOUSING	1-17
HOUSING - SUB-ZERO OPTION	1-24
OUTPUT	1-19
OUTPUT - SUB-ZERO OPTION	1-26
STEERING PARTS	1-15
STEERING PARTS - SUB-ZERO OPTION	1-22
TURNTABLE BEARING	1-20
TURNTABLE BEARING - SUB-ZERO OPTION	1-27
MASTER DRIVE UNIT ASSEMBLY	
TRACTION MOTOR ASSEMBLY/MASTER DRIVE UNIT ASSEMBLY - MANUAL STEERING AND SUB-ZERO, MANUFACTURING OPTION	1-28
MASTER DRIVE UNIT ASSEMBLY AND ATTACHING PARTS	
SUB-ZERO OPTION	1-21
O	
OPERATOR TRAY	6-8
P	
PARKING BRAKE ASSEMBLY	3-6
PREMIUM BACK PAD	6-10
R	
RF TERMINAL	6-2
T	
TANDEM LOAD WHEEL KITS	
TELEMETRY KITS	7-2
THROTTLE SWITCH ASSEMBLY	3-8
TILLER ARM ASSEMBLY	3-14
TILLER HANDLE	
SIDE GLIDE - 17 INCH	3-12
SIDE GLIDE - 25 INCH	3-13
STANDARD - 17 INCH	3-10
STANDARD - 25 INCH	3-11

TABLE OF CONTENTS (continued)

DESCRIPTION	PAGE
TILLER HEAD ASSEMBLY	3-2
TRACTION MOTOR ASSEMBLY	1-4
TRACTION MOTOR INSTALLATION	1-2
V	
VISUAL ALARM	6-4
W	
WIRE HARNESS	
FOOT SWITCH	2-29
MAIN	2-12
MAIN - ALTERNATE PART, PAGE 1 OF 2	2-16
MAIN - ALTERNATE PART, PAGE 2 OF 2	2-20
PUSH BUTTON	2-24
RF TERMINAL	2-26
STROBE LIGHT	2-28
TILLER HANDLE	2-22

ABBREVIATIONS QUICK REFERENCE SHEET

Listed below are abbreviations used in parts manuals to denote the following expressions:

TERM	DEFINITION	TERM	DEFINITION
Amp	Amperes	FRE	Freezer Environment
AR	As Required	in.	inches
BDI	Battery Discharge Indicators	LPG	Liquefied Petroleum Gas
BWI	Brush Wear Indicator	MAP	Manifold Absolute Pressure
CE	Communicator End	mm	millimeters
CRE	Corrosive Environment	MSTS	Microprocessor Spark Timing System
D/B	Date Break	NPT	National Pipe Threads
dbA	Decibel "A" Scale	O/S	Oversize
DE	Drive End	PTO	Power Take Off
ECH	Empty Container Handler	RPM	Revolutions per Minute
ECH-3	Empty Container Handler - 3 High Stacking	S/N	Serial Number
ECH-4	Empty Container Handler - 4 High Stacking	TMM	Truck Management Module
ECH-5	Empty Container Handler - 5 High Stacking	UL Type D	Diesel-Powered Safety Rating
ECH-6	Empty Container Handler - 6 High Stacking	UL Type DS	Diesel-Powered Safety Rating
ECH-7	Empty Container Handler - 7 High Stacking	UL Type E	Battery-Powered Safety Rating
ECM	Electronic Control Module	UL Type EE	Battery-Powered Safety Rating
ECN	Engineering Change Notice	UL Type ES	Battery-Powered Safety Rating
EEPROM	Electrically Erasable Programmable Read Only Memory	UL Type G	Gasoline-Powered Safety Rating
EPA	US Environmental Protection Agency	UL Type GS	Gasoline-Powered Safety Rating
EPROM	Electrically Programmable Read Only Memory	UL Type LP	Gas-Powered Safety Rating
		UL Type LPS	LP Gas-Powered Safety Rating
		U/S	Undersize
		UL	Underwriters Laboratory
		V	Volts

HOW TO USE THE ILLUSTRATED PARTS MANUAL

This parts manual describes and illustrates assemblies, subassemblies, and detail parts needed for service replacement.

The different constructions are indicated by keys and footnotes. The callouts correspond to descriptions found on the next page.

HYSTER UNIT CODE D001 NORTH AMERICA 06/2001

TABLE OF CONTENTS

DESCRIPTION	PAGE
AIR INTAKE AND FILTER DIESEL (→ D/B 11/98).....	3-22
AIR INTAKE AND FILTER DIESEL (D/B 11/96 →).....	
AIR INTAKE AND FILTER GASOLINE AND LPG.....	
ALTERNATOR GASOLINE, LPG, AND DIESEL.....	
ALTERNATOR TYPES GS, LPS, AND DS.....	
AUXILIARY FUNCTION TUBE TWO AND THREE STAGE FULL P.....	

SECTION 13 NUMERICAL INDEX

PART NO.	PAGE NO.	ITEM NO.	PART NO.	PAGE NO.	ITEM NO.	PART NO.	PAGE NO.	ITEM NO.	PART NO.	PAGE NO.	ITEM NO.
142	3-4	19	10-13	25		11-27	29	12-31	12		12
12445	3-32	19	10-17	6		11-31	25	16719	3-36		5
	3-34	1	10-27	11		11-32	37	16751	3-16		27
			11	11		8-4	29	16849	3-34		21
			11	6	16485	8-4	45	16863	3-36		20
			12	13		8-4	34	16865	3-28		17
			12	6		9-7	9	16865	3-6		18
			3	17		9-7	19	16882	4-27		41
			9	10		9-11	9		9-7		30
			23	46		9-11	17		10-10		36
			27	46		10-9	21		10-13		32
			26	14		10-9	28		11-7		24
			28	14		10-13	16		11-9		17
			50	14		11-7	19				

SECTIONS

- 1
- 2
- 3
- 4
- 5
- 6
- 7
- 8
- 9
- 10
- 11

TRANSMISSION HOUSING
S/N D001H-2628

KEY:
A: Diesel
B: Gasoline and LPG

ITEM	PART NO.	DESCRIPTION	QTY	
			A	B
		Transmission	1	1
		Case	1	1
1	2021670	Bearing Cap	2	2
2	2023418	Washer	4	4
3	296429	Bolt	4	4
4	293947	Cover	1	1
5	2021390	Collar Pin	2	2
6	1371656	O-Ring	4	4
7	2021329	Plug	1	1
8	2021915	Housing	4	4
9	2021675	Pin	22	22
10	2021336	Bolt	39	39
11	287860	Lockwasher	1	1
12	292682	Hydraulic Pump	1	1
13		Figure 5-3	8	8
14	2021345	Gasket	1	1
15	214364	Bolt	1	1
16	296418	Washer	1	1
17	2021388	Temperature Switch	1	1
18	2021389	Breather	9	9
19	2021383	Dipstick	9	9
20	292515	Bolt	2	2
21	136692	Nut	3	3
22	292527	Bolt	3	2
23	292531	Capscrew	4	4
24	292583	Lockwasher	4	4
25	293637	Bolt	4	4
26	296420	Washer	1	1
	996403	Transmission Kit (Includes Item 7)	1	1
	996405	Transmission Kit (Includes Item 14)	1	1

This Parts Manual is divided into 11 major sections which are listed above. Quick reference can be made by placing the right thumb on the tab of the desired section, bending the pages to the corresponding tab.

© Copy Right Date HYSTER COMPANY See Service Manual for service procedures. 5-15

HOW TO FIND THE DESIRED PART NUMBER

WHEN THE PART NUMBER AND THE NEXT HIGHER ASSEMBLY IS NOT KNOWN:

1. Determine the function and application of the part required. Turn to the Sections Page. Choose the general area of reference most likely to include the part.
2. Turn to the section you chose. Use the Section Table of Contents to determine the assembly which would normally contain the part required. Then locate the part on the assembly breakdown page.

WHEN THE PART NUMBER IS NOT KNOWN AND THE NEXT HIGHER ASSEMBLY IS KNOWN:

3. Determine the assembly the required part is used on. Turn to the Table of Contents (Page i).
4. Locate the assembly the required part is used on and turn to the page indicated for that assembly. Then locate the part on the assembly breakdown page.

WHEN THE PART NUMBER IS KNOWN:

5. Use the Numerical Index (Page 8-1) to find the part number. Turn to the page listed and locate the part as indicated by the item number.

GENERAL:

The assembly breakdowns include part numbers, descriptions, quantities required, keys and footnotes to help in selecting correct parts.

6. Parts Supersession Information. Part numbers that have this history will be displayed in the parts list in the order that they were superseded (from oldest to newest). The superseded part numbers will be shown with a line through them.

Five periods in the PART NO. column (.) indicate that the part is either *Not Serviced Separately* or there is a reference to another figure. A figure reference is denoted by a pointing hand followed by a figure number in the DESCRIPTION column (☞ Figure 10)

7. Keys are used to show two or more similar assemblies, RH and LH assembly parts, etc. Select the appropriate key, "A", "B", "C", "D", or "E" and the corresponding quantity column to find the required parts. Two periods in the QTY column (..) indicate that the part is not used for that assembly.
8. Indented descriptions under the DESCRIPTION column are used to indicate assemblies and

subparts of assemblies. In the example on the previous page, *BEARING CAP* (Item 2) is a subpart of the major assembly *CASE*.

9. Quantities shown are for one assembly. The quantities of the subpart *BEARING CAP* are indicated as two and two. This means two per *CASE* assembly.
10. Serial number breaks identify the most current parts information and are shown as follows:
 - **S/N D001H2628**
Indicates last serial number affected.
 - S/N D001H2629** →
Indicates the first serial number affected.
 - S/N D001H1553** ↔ **S/N D001H3291**
Indicates a range of serial numbers affected.

ECN numbers for pending serial numbers are shown to allow for the inclusion of the most current parts information and are identified as follows:

- **S/N Pending Per ECN 63243**
Indicates a pending serial number for last unit affected.
- S/N Pending Per ECN 63243** →
Indicates a pending serial number for first unit affected.

Date breaks are used to indicate when a change occurred but a subsequent serial number break was not recorded. This is an arbitrary date usually based on the ECN release and are identified as follows:

- **D/B 3/00**
Indicates that a change occurred sometime within that month for the item affected.
- D/B 3/00** →
Indicates that a change occurred sometime within that month for the item affected.
- D/B 3/00** ↔ **D/B 4/00**
Indicates a range of production dates of the item affected.

Contact your local dealer for Hyster lift trucks for serial number information for items with a ECN or a date break.

ORDERING PARTS:

When ordering replacement parts, give the unit serial number, part number, name of part and quantity required.

For any further information on parts, service, or ordering, consult your local dealer for Hyster lift trucks.

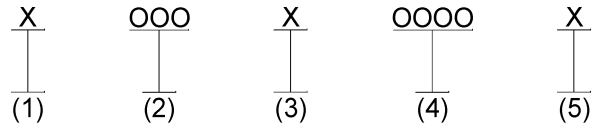
IDENTIFICATION OF TRUCK SERIAL NUMBERS

- (1) and (2) The first letter and three numbers indicate the truck unit code.
- (3) The second letter indicates the plant of manufacture.
- (4) The four or five digit number indicates the production sequence number of the truck.
- (5) The final letter indicates the year of manufacture starting with "A" in 1957, 1980, and 2003.
The letters "I", "O", and "Q" will not be used.

For pending serial numbers contact your local dealer for Hyster lift trucks.

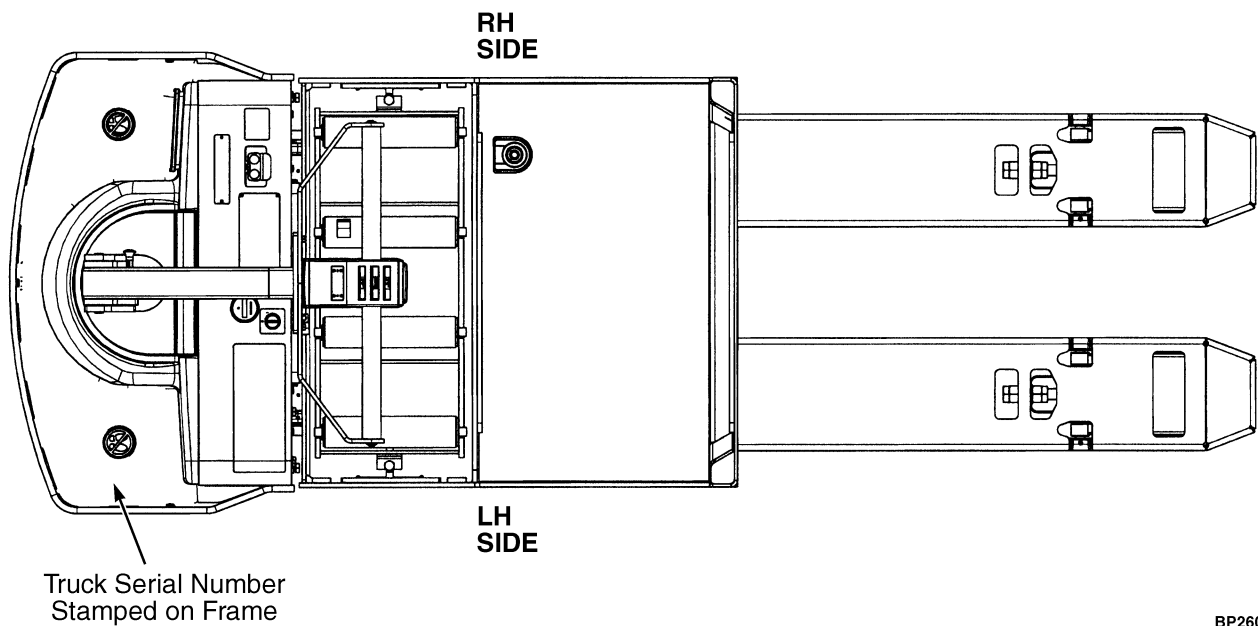

BP260010

Parts referred to in this book as right or left hand parts are in accordance with the illustration above.

PUBLICATIONS

Every new lift truck is provided with an OPERATING MANUAL. This manual has information that the operator must know for inspection and operation of the lift truck.

SERVICE MAINTENANCE MANUALS, which provide service and overhaul procedures, and PARTS

MANUALS with complete replacement part identification, are available at a nominal fee from your Hyster dealer to assist users in effectively maintaining Hyster lift trucks in a safe, useful condition. See the list below for information on ordering specific publications for this model lift truck.

PUBLICATION	HYSTER PART NUMBER
Operating Manual.....	4092803
Service Manual (Complete).....	4096029
Parts Manual.....	4092807

1

FRAME/DRIVE UNIT

SECTION 1 FRAME/DRIVE UNIT

DESCRIPTION	PAGE
BATTERY RETENTION	1-7
BATTERY ROLLER ASSEMBLY	1-8
COVERS AND FLOORMAT	1-10
DECALS	1-12
DRIVE WHEEL AND TIRE AND STATIC STRAP	1-6
MASTER DRIVE UNIT	
CARRIER	1-16
CARRIER - SUB-ZERO OPTION	1-23
DRIVE	1-18
DRIVE - SUB-ZERO OPTION	1-25
HOUSING	1-17
HOUSING - SUB-ZERO OPTION	1-24
OUTPUT	1-19
OUTPUT - SUB-ZERO OPTION	1-26
STEERING PARTS	1-15
STEERING PARTS - SUB-ZERO OPTION	1-22
TURNTABLE BEARING	1-20
TURNTABLE BEARING - SUB-ZERO OPTION	1-27
MASTER DRIVE UNIT ASSEMBLY	
TRACTION MOTOR ASSEMBLY/MASTER DRIVE UNIT ASSEMBLY - MANUAL STEERING AND SUB- ZERO, MANUFACTURING OPTION	1-28
MASTER DRIVE UNIT ASSEMBLY AND ATTACHING PARTS	1-14
SUB-ZERO OPTION	1-21
TRACTION MOTOR ASSEMBLY	1-4
TRACTION MOTOR INSTALLATION	1-2

TRACTION MOTOR INSTALLATION (FIGURE 1-1)

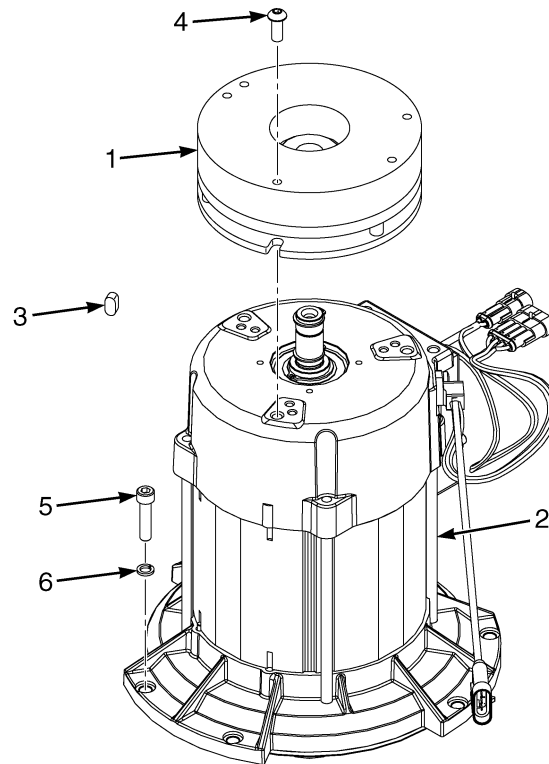

BP160117

ITEM	PART NO.	DESCRIPTION	QTY
1	2084747	Magnetic Brake Assembly (With Diode) (A282) (Shown)	1
1	2085166	Brake Assembly , Magnetic (With Diode) (A373)	1
2	4061344	Traction Motor Assembly (☞ Figure 1-2).....	1
3	2045959	Key (Woodruff)	1
4	296166	Capscrew (A282 Only)	3
5	296013	Capscrew	6
6	293780	Lockwasher	6

TRACTION MOTOR ASSEMBLY (FIGURE 1-2)

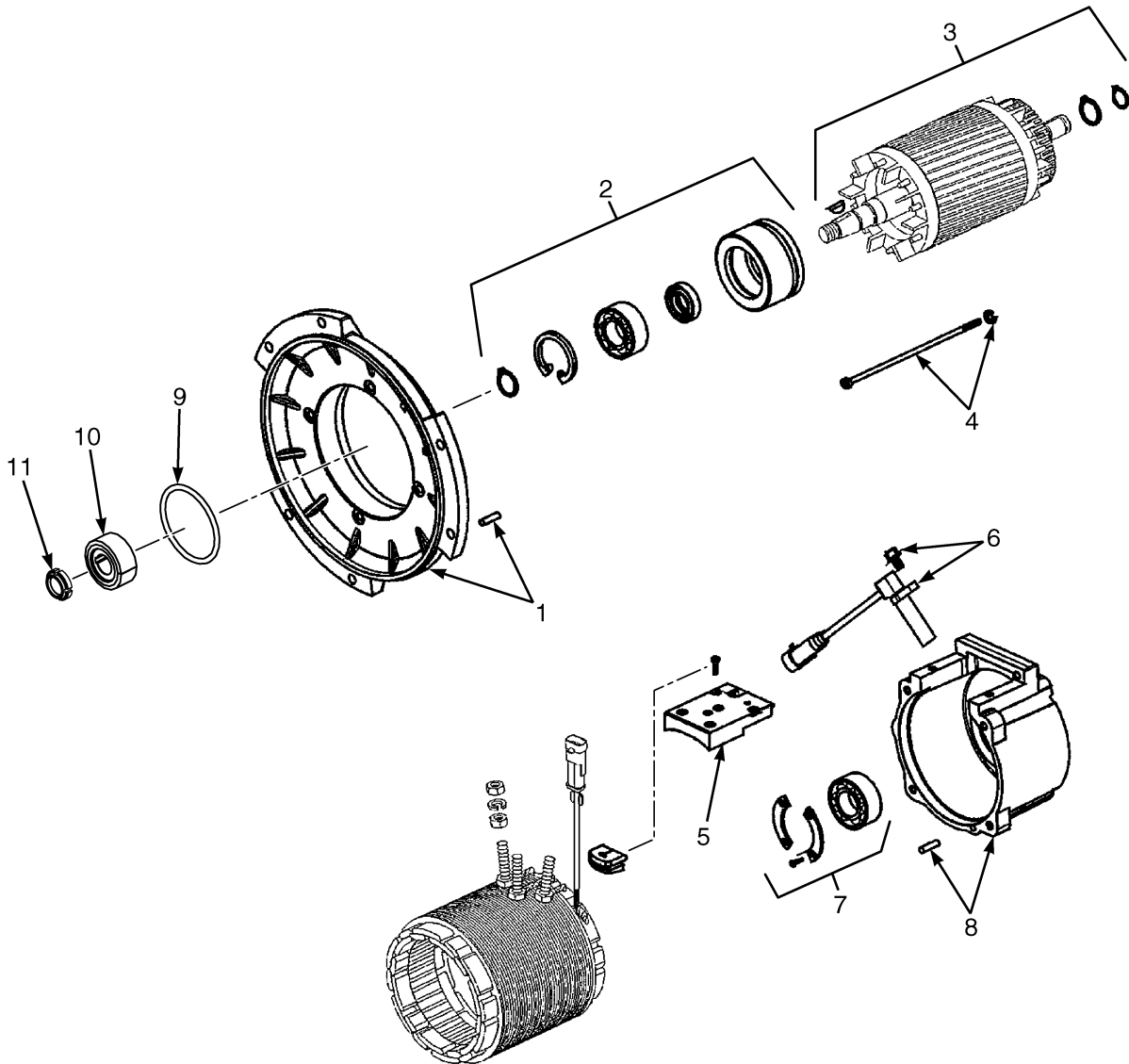

BP160116

TRACTION MOTOR ASSEMBLY

ITEM	PART NO.	DESCRIPTION	QTY
	4061344	Traction Motor Assembly	1
	4621595	Traction Motor	1
1	4078440	Bracket , Drive End	1
2	4078441	Retainer Assembly (Bearing)	1
3	4078442	Snap Ring Assembly and Key	1
4	4078443	Bolt , Fixing	1
5	4078444	Plate , Connection	1
6	4078445	Sensor	1
7	4078446	Bearing	1
8	4078447	Bracket , Rear End	1
9	4061542	O-Ring	1
10	4056662	Gear (Input Pinion)	1
11	4052389	Locknut (Elastic Stop Nut)	1